

KINNEY AUTOMATIC SELF-CLEANING STRAINER

Bulletin 513.1
MODEL AP-1
(Fabricated)

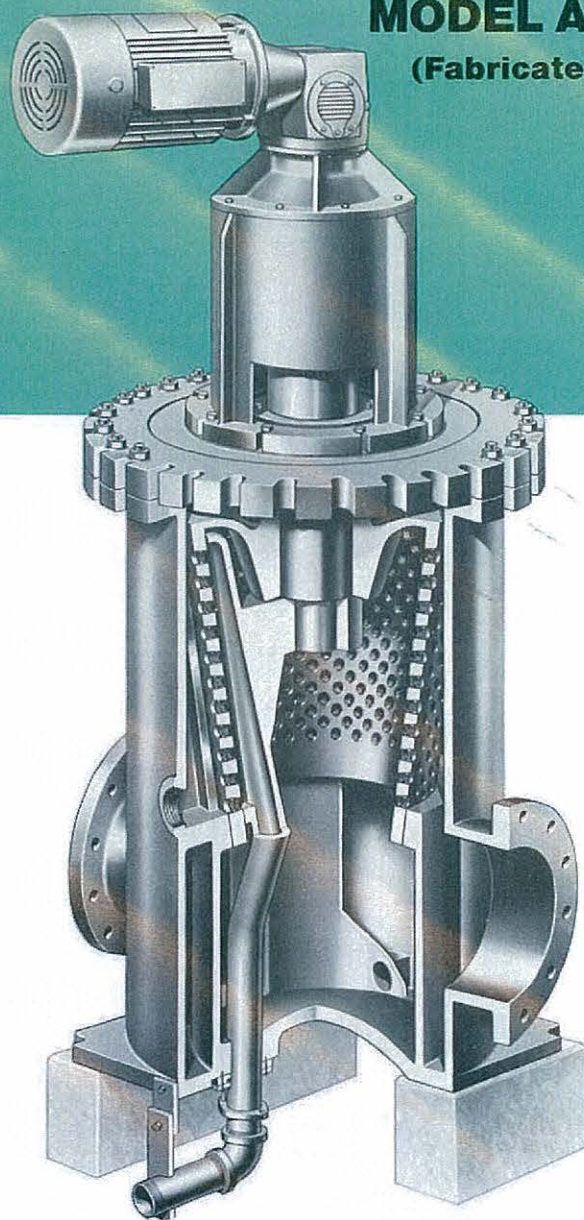

APPLICATIONS

Designed for continuous removal of suspended particles from all types of liquids. Applications are in industrial plants using river, lake, well, or sea water for cooling, descaling, bearing lubrication, spraying, quenching, and similar purposes. Pipe-line sizes: 8"-42" or larger upon application.

Liquids other than water, such as chemicals, acids, white water (paper mills), sewage, and ammonia flushing liquor (coke plants) can also be effectively strained.

INSTALLATION

Used when working pressure is low. The strainer is compact—with small face-to-face, width, and height dimensions.

DESIGN

The strainer consists of a cylindrical drum with a number of drilled and threaded holes containing one of many types of straining media. The drum is supported on a rotating shaft fitted with bearings and is contained in a body having a vertical backwash slot opening. A pressure backwash shoe is inserted inside the drum, directly opposite the backwash slot.

OPERATION

The liquid to be strained enters the inlet connection located in the lower portion of the body and flows around the outer surface of the drum. The suspended particles are retained in the media pockets and the clean liquid passes through the media to the inside and bottom opening of the drum—leaving the body at the outlet connection located diametrically opposite the inlet.

BACKWASH

High pressure liquid from the discharge side of the pump or from some other source is diverted to the backwash shoe. As each row of straining media passes between the backwash shoe and the backwash slot, the high pressure liquid flushes the suspended particles from the media. The amount of high pressure liquid needed to effect proper backflushing is low and will vary, depending on the amount of suspended particles in the liquid being strained. The inlet and outlet valves are kept open partially in order to obtain a minimum pressure drop across the strainer with low wastage. Periodically, these valves should be opened all the way to obtain a more thorough cleaning action. The backwash piping should discharge into an open funnel immediately after the backwash outlet valve.

AUTOMATIC BACKWASH CONTROL

In lieu of manually operated backwash valves, an automatic control can be furnished to permit intermittent backflushing. This control consists of motor or pneumatic cylinder operated ball valves (one at the backwash inlet and one at the backwash outlet), actuated by a timer.

ADJUSTMENT AND SHEARING ACTION

The clearance between the backwash slot and the drum and the clearance between the drum and the backwash shoe is equal to or smaller than the opening presented in the media. Adjustment of the clearance between the backwash slot and the drum is accomplished by two locknuts on the threaded part of the top section of the shaft. The clearance between the drum and the backwash shoe is adjusted at the bottom of the backwash shoe.

The backwash slot contains a knife-like edge which enables the strainer to shear debris such as wood, shells, fish, and other suspended materials which may extend beyond the surface of the drum—with no resultant damage to the drum, straining media, or drive unit.

INSPECTION

The Kinney strainer eliminates troublesome disassembly by providing an opening in the side of the strainer body. To inspect the straining media, simply remove the cover and manually rotate the drum (via a special shaft in the drive unit). As each row of media passes the inspection opening, easy access to the media is achieved.

MODEL AP-1

Fabricated

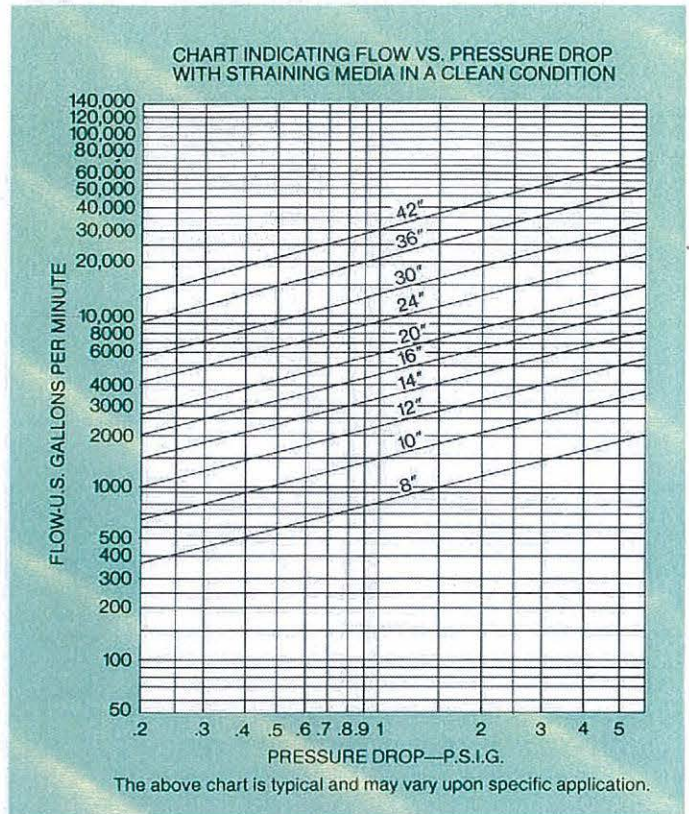
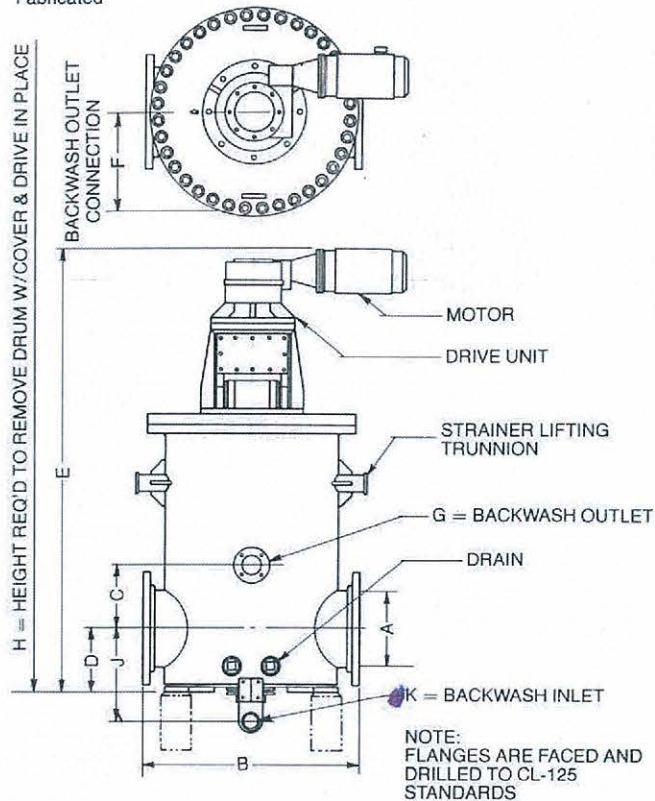

MODEL AP-1 FABRICATED										
STRAINER SIZE-A	DIMENSIONS (INCHES)									APPROX. SHIP. WT. LBS.
	B	C	D	E	F	G	H	J	K	
8	21	8	8	51½	10½	2 ▲	81¼	13¾	1½	1,220
10	28	9	9¼	61¼	12½	2 ▲	99	14¾	1½	1,835
12	31	10¾	10½	64½	16¼	3 ▲	107½	16¾	2	2,495
14	36	12½	12	80¼	19	3 ▲	133¾	19¾	2½	3,650
16	41	13½	13¼	83¾	19	4	139¾	20¾	2½	4,540
18	45	14	14¼	93¼ ₁₆	20¾	3*	164½	23¼	3	6,565
20	45	15¼	14¾	96½	20¾	3*	165¼	24½	3	6,655
24	52	16½	17½	105¾ ₁₆	24¼	4*	179½	26¾	4	9,180
30	62	20½	20½	122¾	28½	4*	223½	31¾	4	12,720
36	72	26½	25	137	32¾	6*	237	42¾	6	18,400
42	86	28½	28	159¾	40	6*	277½	45	6	27,300

*Two backwash openings ▲ Pipe tap Do not use for construction—certified prints will be furnished

CONSTRUCTION				
PART	STANDARD	SEA WATER	WHITE WATER	AMMONIACAL LIQUOR
BODY	Fabricated Steel (Epoxy Lined)	Fabricated Steel (Epoxy Lined) or Stainless Steel	Stainless Steel	Fabricated Steel
DRUM	Cast Iron	Ni-Resist	Stainless Steel	Cast Iron
MEDIA	As Specified	As Specified	As Specified	As Specified
MEDIA RETAINERS	Delrin	Stainless Steel	Delrin	Stainless Steel
SHAFT	Steel	Stainless Steel	Stainless Steel	Stainless Steel
BACKWASH SHOE (Model AP only)	Cast Iron	Ni-Resist	Stainless Steel	Cast Iron



S. P. KINNEY ENGINEERS, INC.
 143 FIRST AVE. • CARNEGIE, PENNSYLVANIA 15106
 PHONE: AREA CODE (412) 276-4600