

KINNEY AUTOMATIC SELF-CLEANING STRAINER

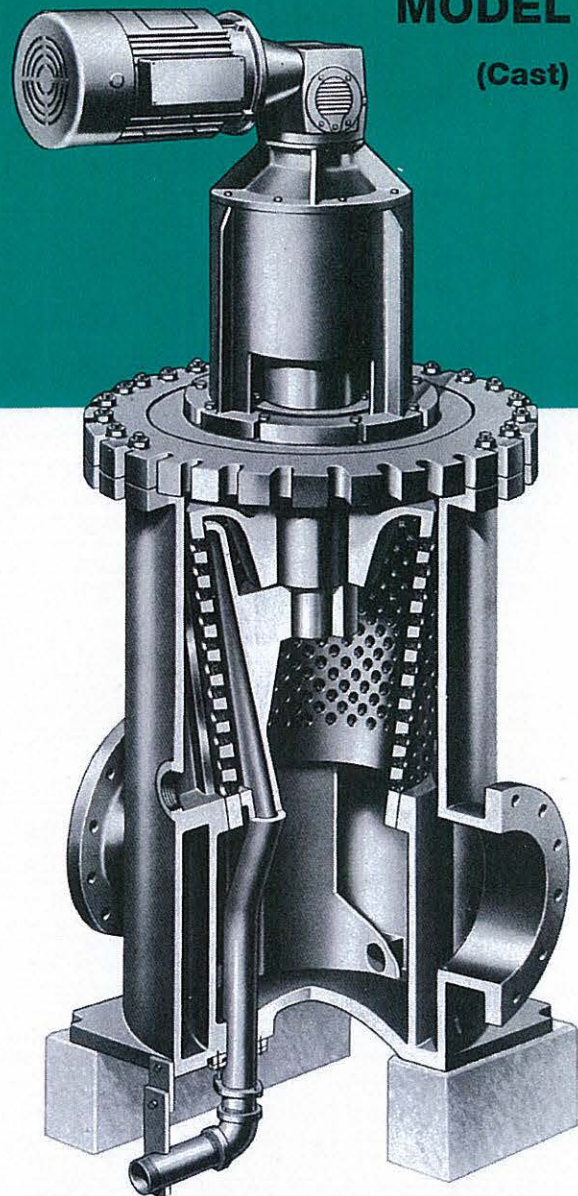

APPLICATIONS

Designed for continuous removal of suspended particles from all types of liquids. Applications are in industrial plants using river, lake, well, or sea water for cooling, descaling, bearing lubrication, spraying, quenching, and similar purposes. Pipe-line sizes: 4"-42" or larger upon application.

Liquids other than water, such as chemicals, acids, white water (paper mills), sewage, and ammonia flushing liquor (coke plants) can also be effectively strained.

INSTALLATION

Used when working pressure is low. The strainer is compact—with small face-to-face, width, and height dimensions.

DESIGN

The strainer consists of a cylindrical drum with a number of threaded holes containing one of many types of straining media. The drum is supported on a rotating shaft fitted with bearings and is contained in a body having a vertical backwash slot opening. A pressure backwash shoe is inserted inside the drum, directly opposite the backwash slot.

OPERATION

The liquid to be strained enters the inlet connection located in the lower portion of the body and flows around the outer surface of the drum. The suspended particles are retained in the media pockets and the clean liquid passes through the media to the inside and bottom opening of the drum—leaving the body at the outlet connection located diametrically opposite the inlet.

BACKWASH

High pressure liquid from the discharge side of the pump or from some other source is diverted to the backwash shoe. As each row of straining media passes between the backwash shoe and the backwash slot, the high pressure liquid flushes the suspended particles from the media. The amount of high pressure liquid needed to effect proper backflushing is low and will vary, depending on the amount of suspended particles in the liquid being strained. The inlet and outlet valves are kept open partially in order to obtain a minimum pressure drop across the strainer with low wastage. Periodically, these valves should be opened all the way to obtain a more thorough cleaning action. The backwash piping should discharge into an open funnel immediately after the backwash outlet valve.

AUTOMATIC BACKWASH CONTROL

In lieu of manually operated backwash valves, an automatic control can be furnished to permit intermittent backflushing. This control consists of motor or pneumatic cylinder operated ball valves (one at the backwash inlet and one at the backwash outlet), actuated by a timer.

ADJUSTMENT AND SHEARING ACTION

The clearance between the backwash slot and the drum and the clearance between the drum and the backwash shoe is equal to or smaller than the opening presented in the media. Adjustment of the clearance between the backwash slot and the drum is accomplished by two locknuts on the threaded part of the top section of the shaft. The clearance between the drum and the backwash shoe is adjusted at the bottom of the backwash shoe.

The backwash slot contains a knife-like edge which enables the strainer to shear debris such as wood, shells, fish, and other suspended materials which may extend beyond the surface of the drum—with no resultant damage to the drum, straining media, or drive unit.

INSPECTION

The Kinney strainer eliminates troublesome disassembly by providing an opening in the side of the strainer body. To inspect the straining media, simply remove the cover and manually rotate the drum (via a special shaft in the drive unit). As each row of media passes the inspection opening, easy access to the media is achieved—optional on sizes 4" and 6".

MODEL AP
Cast

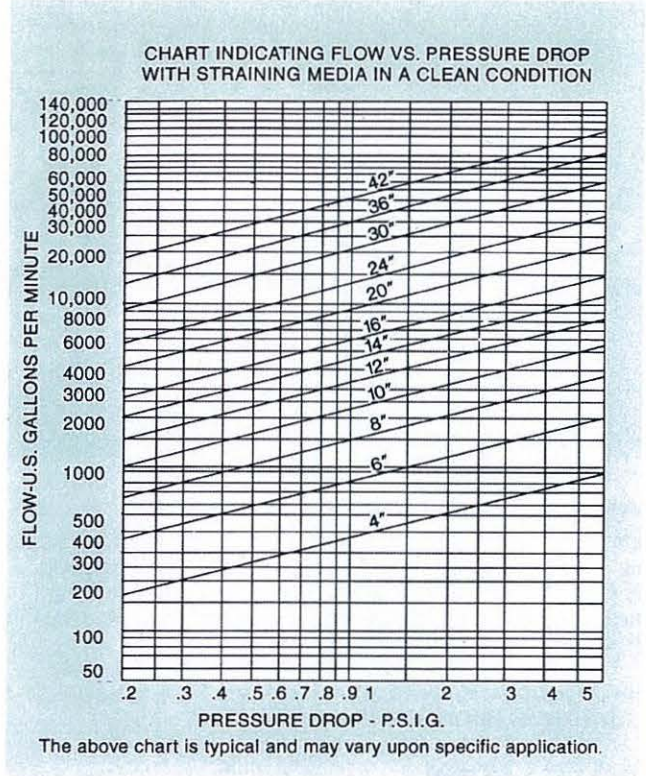
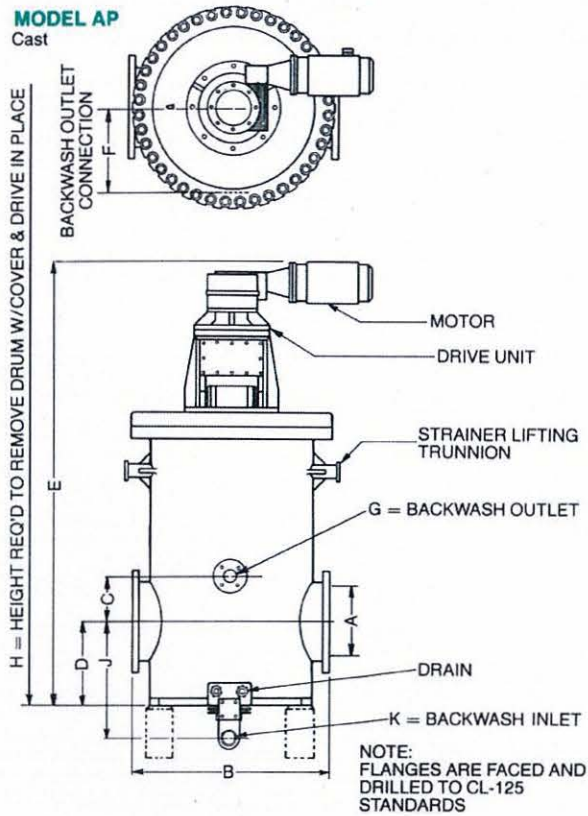

MODEL AP CAST											
STRAINER SIZE-A	DIMENSIONS (INCHES)										APPROX. SHIP. WT. LBS.
	B	C	D	E	F	G	H	J	K		
4	18½	1¼	5	37	6¾	2▲	49	7	1½	645	
6	21	5	9	49	8⅝	2▲	67⅞	6⅝	1½	1,140	
8	26	6⅞	9½	58½	10½	2▲	97¼	15½	1½	1,890	
10	31	8¼	11	65½	13	3▲	108⅞	16¼	2	2,600	
12	36	9¾	12½	81⅞	14¾	3▲	128⅞	18½	2	4,625	
14	41	10½	14½	83⅞	17⅝	4	140	21¼	2½	6,260	
16	45	10½	19¼	101¾	19⅞	3*	169¼	26½	3	8,775	
20	52	13	20	106½	22⅜	4*	192½	28⅞	4	11,830	
24	62	11⅞	23¾	120¾	26⅝	4*	209½	32	4	17,400	
30	72	12½	20	115¾	31	6*	210¼	27½	6	24,000	
36	86	32½	25	165¼	37½	6*	281¼	39	6	39,950	
42	100	36	27	189¼	39½	6*	305¼	41	6	48,500	

*Two backwash openings ▲ Pipe tap Do not use for construction—certified prints will be furnished

CONSTRUCTION				
PART	STANDARD	SEA WATER	WHITE WATER	AMMONIACAL LIQUOR
BODY	Cast Iron	Cast Iron	Cast Iron	Cast Iron
DRUM	Cast Iron	Ni-Resist	Stainless Steel	Cast Iron
MEDIA	As Specified	As Specified	As Specified	As Specified
MEDIA RETAINERS	Delrin	Delrin	Delrin	Stainless Steel
SHAFT	Steel	Stainless Steel	Stainless Steel	Stainless Steel
BACKWASH SHOE (Model AP only)	Cast Iron	Ni-Resist	Stainless Steel	Cast Iron



S.P. KINNEY ENGINEERS, INC.
143 FIRST AVE. • CARNEGIE, PENNSYLVANIA 15106
PHONE: AREA CODE (412) 276-4600